

## Gauge union Model : A020

# WISE®

### Service intended

It is used for positive sealing while the pressure gauge may be directed into any directions



ACCESSORIES FOR PRESSURE GAUGE

### Ordering information

BASE MODEL - 1st thru 4th characters  
A020 : GAUGE UNION

5th Character		6th Character		7th Character		8th Character		9th Character	
Code	Union Type	Code	Material	Code	Gauge Connection Size	Code	Gauge Connection Type	Code	Process Connection Size
N	Pipe Welding	B	S25C	0	1/4"	A	PF(F)	A	1/8"(10.5mm)
P	PF(M)	C	304SS	1	3/8"	B	PT(F)	C	3/8"
Q	PT(M)	D	316SS	2	1/2"	C	NPT(F)	D	1/2"
R	Socket Welding	F	316LSS	3	1/8"			E	3/4"
S	Boss	G	Monel					Q	Flange
T	Flange	H	Hastelloy-C						
		Z	Other	9	Other	Z	Other	Z	Other

10th Character		11th Character		12th Character		13th thru 15th Character	
Code	Process Connection Type	Code	Flange Size	Code	Flange Rating	Code	Pipe Length
C	NPT(F)	A	N/A	A	N/A	000	3/8" SCH 40(17.3ø × 2.3t), 100mm
G	PF(M)	D	1/2"(15A)	B	ANSI 150# RF	010	3/8" SCH 80(17.3ø × 3.2t), 100mm
H	PT(M)	E	3/4"(20A)	C	ANSI 150# FF	020	1/2" SCH 40(21.7ø × 2.8t), 100mm
J	NPT(M)	F	1" (25A)	D	ANSI 150# RFSF	030	1/2" SCH 80(21.7ø × 3.7t), 100mm
M	S.W(F)	G	1 1/4"(32A)	E	ANSI 300# RF		
N	S.W(M)	H	1 1/2"(40A)	F	ANSI 300# FF		
P	Pipe Welding	J	2" (50A)	G	ANSI 300# FFSF		
Q	Flange			H	ANSI 600# RF		
				J	ANSI 600# FF		
				K	ANSI 600# RFSF		
				L	JIS 10K RF		
				M	JIS 10K FF		
				N	JIS 10K RFSF		
				P	JIS 20K RF		
				Q	JIS 20K FF		
				R	JIS 20K RFSF		
				S	JIS 30K RF		
				T	JIS 30K FF		
				U	JIS 30K RFSF		
Z	Other	Z	Other	Z	Other		

# A020 : Gauge union

ACCESSORIES FOR PRESSURE GAUGE

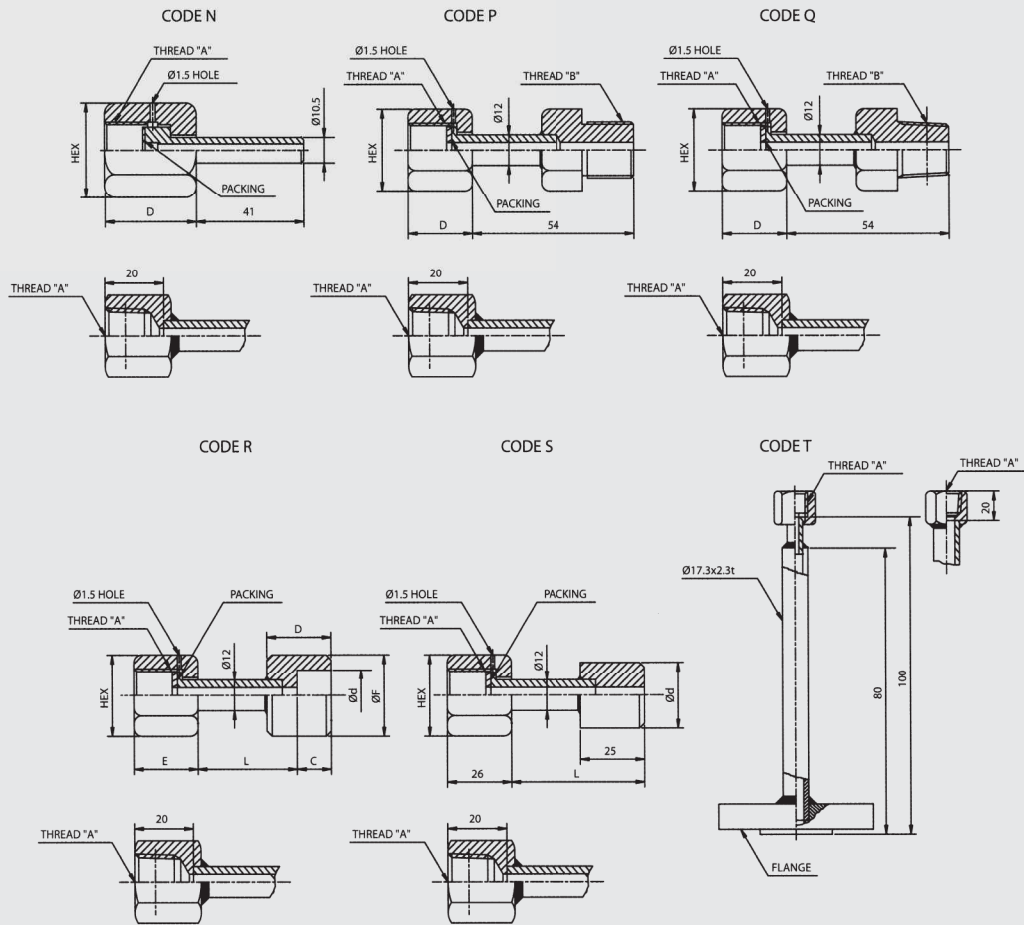

Dimensions (mm)

CODE	A		B	D	CODE	A		d	C	D	E	F	L
N	PF	3/8		26	R	PF	3/8	3/8B	10	22	26	26	42
	(N)PT	1/2		28				1/2B				32	
P	PF	3/8	PF3/8	26				(N)PT	1/2	3/4B		13	
			PF1/2			10	22			3/8B	32		
			PF3/4							3/4B	13	25	40
	(N)PT	1/2	PF3/8	28		PF	1/2	3/8B					45
			PF1/2		1/2B								
			PF3/4		3/4B								
Q	PF	3/8	(N)PT3/8	26	T	PF	3/8	FLANGE RATING				FF	
			(N)PT1/2					10,16,20, 30,40K	15,20,25, 32,40,50A		RF		
			(N)PT3/4						150,300, 600LB	1/2,3/4,1, 11/4,11/2,2B			
	(N)PT3/8	28	PF	3/8		ANSI (JPI)				RF			
	(N)PT1/2						(N)PT	1/2					
	(N)PT3/4												